

INSTALLATION & OPERATION MANUAL



INFINITY

PROTECTOR
WHOLE HOUSE WATER FILTER

WATER  **TECH**
FILTRATION SYSTEMS

CERTIFIED 
WATER PROTECTION 



MODEL: INF-PRO1

INFINITY PROTECTOR

PRODUCT FEATURES & PRECAUTIONS

MODEL: INF-PR01

Certified Safety & Performance to Reduce:

Lead

PFAS (PFOA/PFOS)

Cysts (Giardia & Crypto)

Also Addresses*:

Chlorine & Chloramines

Pharmaceuticals & Contaminants

Volatile Organic Compounds (VOCs)

Sediment

*Internal data only. Level of reduction has not been verified by IAPMO R&T

PRECAUTIONS



Filter is only to be used with cold water.



The contaminants or other substances removed or reduced by this water filter are not necessarily in all users' water.



Testing was performed under standard laboratory conditions, actual performance may vary.



System has been designed and tested to be used on municipally treated water sources. Do not use with water that is microbiologically unsafe or of unknown water quality without adequate disinfection before or after the system.



Filter usage must comply with all state and local laws and regulations.



Manufactured from NSF/ANSI standard 61 and California Prop 65 Compliant certified coconut shell carbon and raw materials.

INSTALLATION OF INFINITY

WHERE TO INSTALL

1

CITY WATER

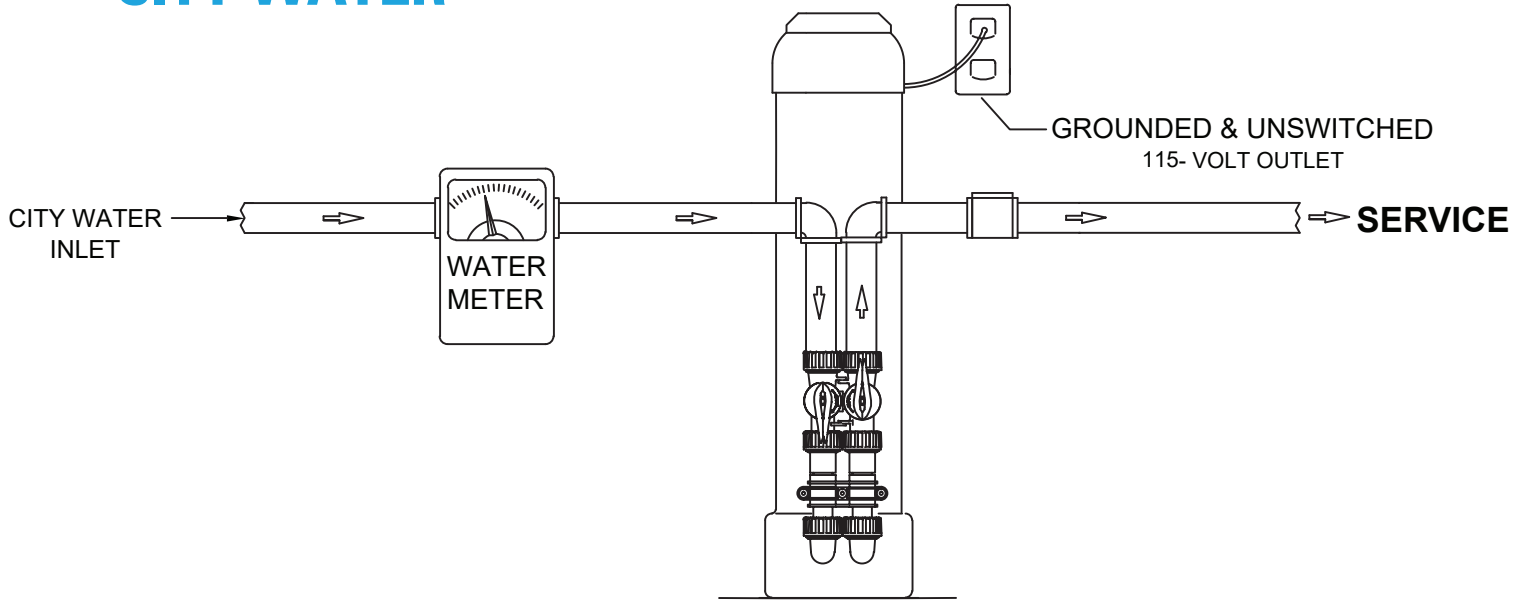

WELL WATER

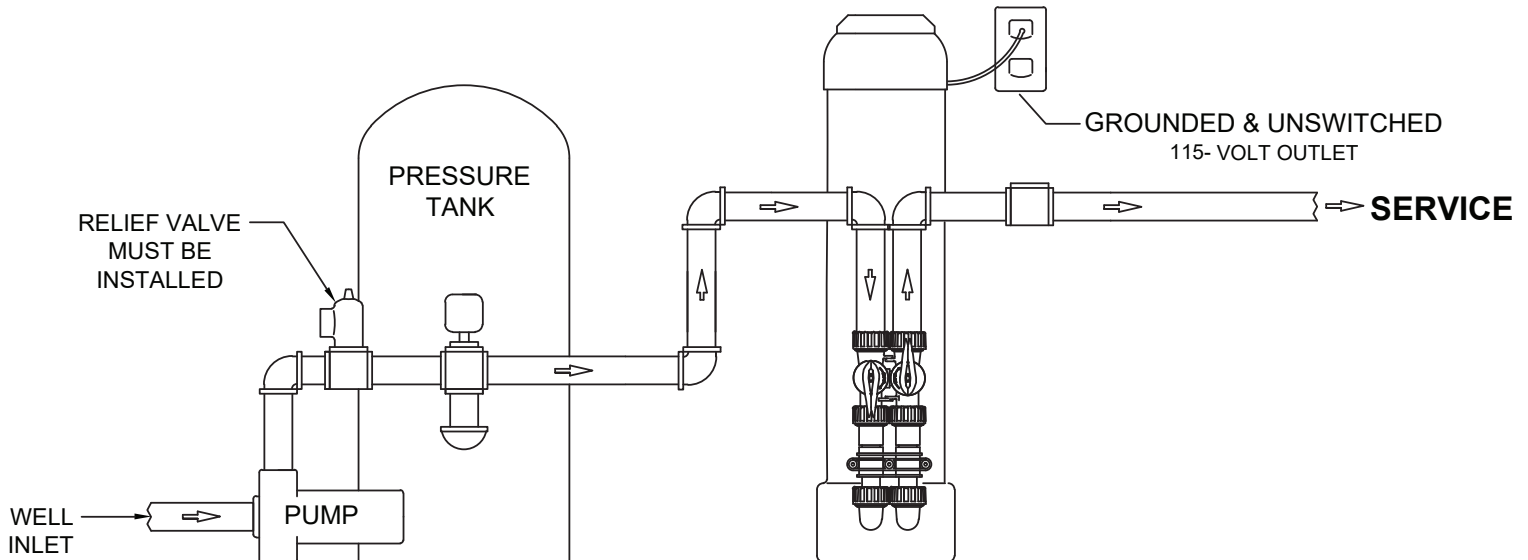

INSTALLATION OF INFINITY PRODUCTS & PARTS DIAGRAM

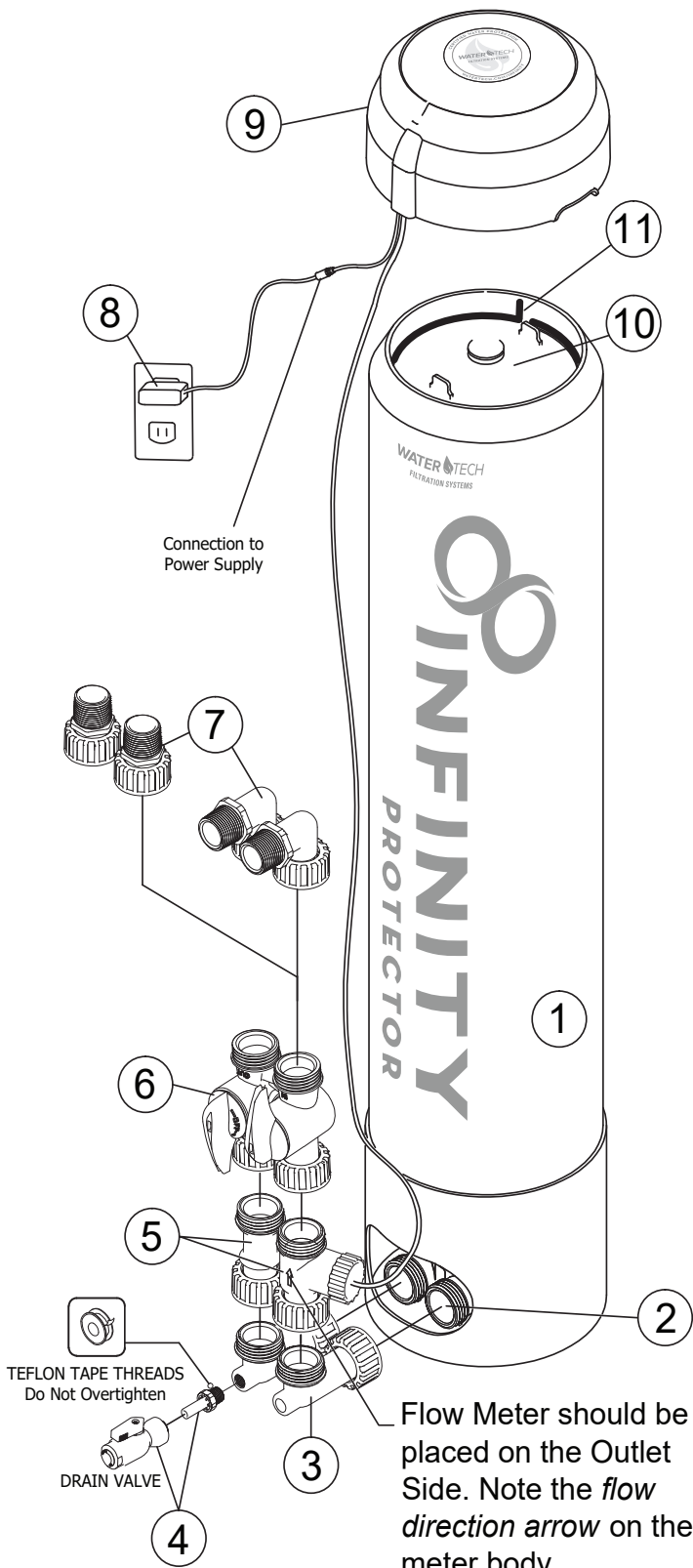

PARTS

1. Filter housing (10-00-001)
2. Bottom Inlet/Outlet cap assembly (10-00-002)
3. Vertical elbow (10-00-003)
4. 3/8" PEX Drain valve assembly with shut-off (10-00-004)
5. Flow Meter Assembly (10-00-005)
6. Bypass manifold (10-00-006)
7. Straight or 90-degree Angled In/Out 1" MNPT plumbing connectors (10-00-007)
8. Power Supply (10-00-008)
9. Umbrella Cap with PCB assembly and battery backup (10-00-009)
10. Top Cap (10-00-010)
11. Retaining Ring (10-00-011)
12. Replacement Filter (INF-PRO1-FX)

6 Bypass Orientation

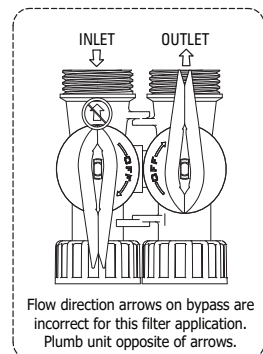

The system and installation must comply with state and local laws and regulations.

Plumbing the filtration system assembly: The inlet and outlet of the filtration housing are 1" Threaded MNPT connections.

**No Use of Extra lubricants, unapproved sealants, and use of tools. Use of tools other than hand tighten only parts, voids warranty.

Please allow 3 feet of open space above the system for replacement cartridges.

System to be supplied only with cold water.

3-AAA batteries not included.

Meter assembly preset to 100,000 gallons

INSTALLATION OF INFINITY SIMPLE ASSEMBLY INSTRUCTIONS

NOTE: Additional parts box inside filter housing tank.

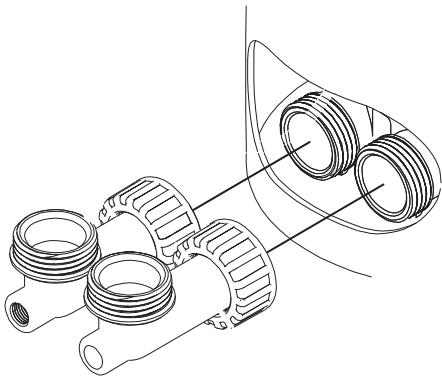

STEP 1

Connect #3 to #2 on the bottom of the Filter Housing #1.
HAND TIGHTEN ONLY

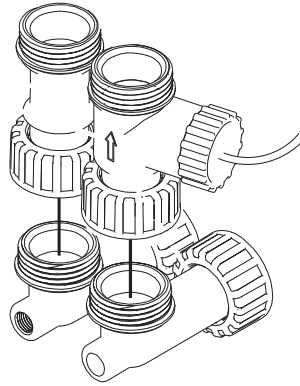

STEP 2

Connect #5 to #3; Flow Meter Assembly should be placed on the Outlet Side.
(Note the flow direction arrow on the meter body)
HAND TIGHTEN ONLY

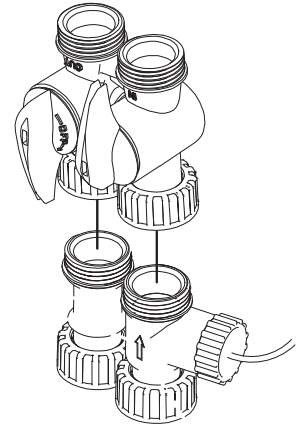

STEP 3

Connect #6 Bypass to #5
HAND TIGHTEN ONLY

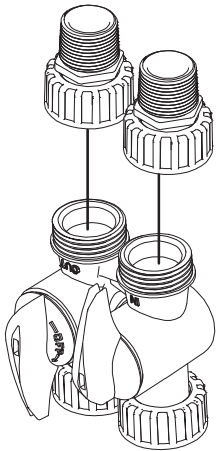

STEP 4 OPTION A

Use #7 (Straight In/Out 1" MNPT) for connecting your plumbing to the system.
HAND TIGHTEN ONLY

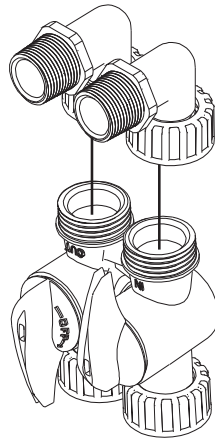

STEP 4 OPTION B

Use #7 (90-degree Angled In/Out 1" MNPT) for connecting your plumbing to the system.
HAND TIGHTEN ONLY

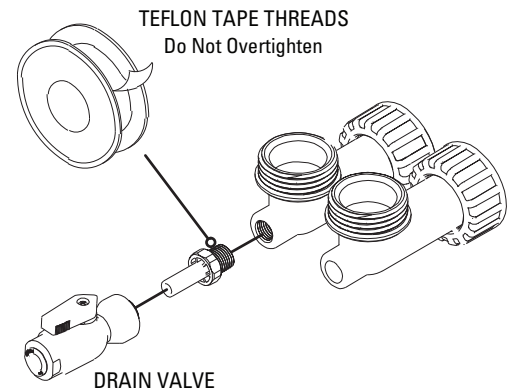

STEP 5

Install part #4 into #3 using the threaded connection & Teflon® tape.
HAND TIGHTEN ONLY

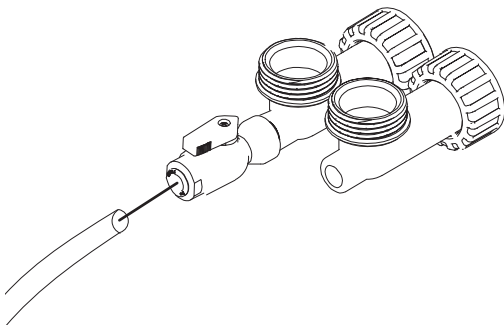

STEP 6

Connect 3/8" PEX Plumbing to drain.
NOT PROVIDED

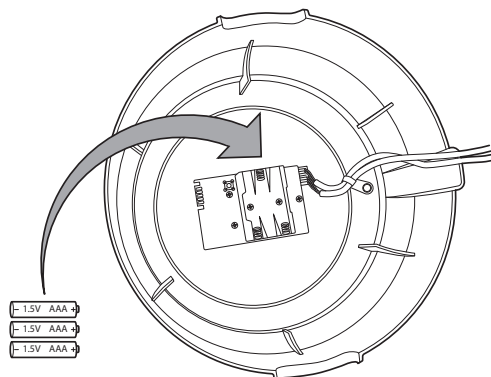

STEP 7

Install 3-AAA batteries on Umbrella Cap.

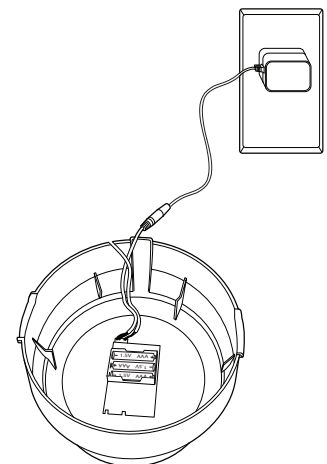

STEP 8

Connect Power Supply to Umbrella Cap cord & to wall.

INSTALLATION OF INFINITY FILTER CARTRIDGE INSTALLATION

4

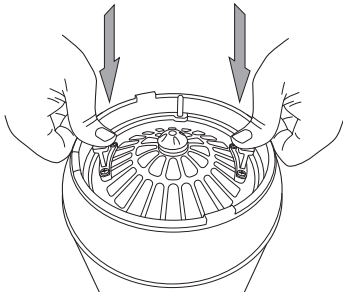

STEP 1

Push down the top cap with both hands.

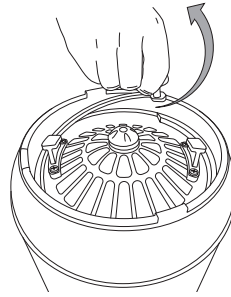

STEP 2

Remove the retaining ring by carefully grasping the handle and pulling inward, then upward. The retaining ring should slide completely out of the groove.

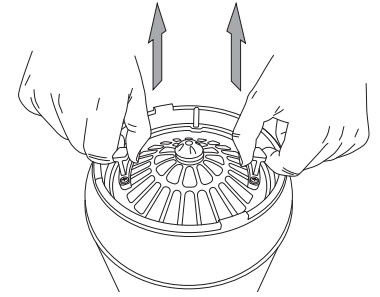

STEP 3

Remove the Top Cap from the housing assembly by pulling the cap out of the top of the tank, by lifting up on the top handles. Place removed Top Cap on a clean and dry surface, free of debris, so no contamination of the o-ring occurs.



STEP 4

Look down into the tank assembly, and you should see a small opening centered in the bottom of the tank.



STEP 5

Remove packaging from filter cartridge, then place the filter cartridge into the tank with the double O-ring facing down.



STEP 6

Position the cartridge so that it is aligned with the bottom, center opening.

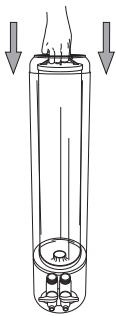

STEP 7

Press down on the filter cartridge so that the double O-ring seal moves into place within the bottom, center opening.

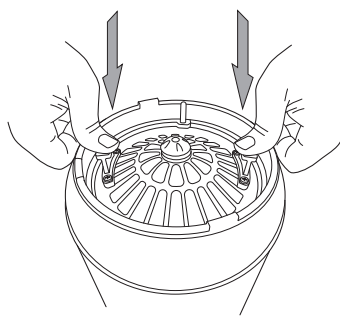

STEP 8

Reposition the Top Cap into its original location.

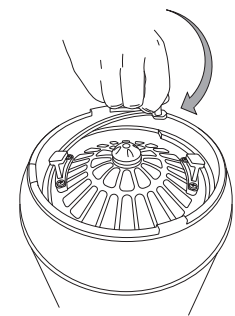

STEP 9

Reattach the top tank Snap Ring.

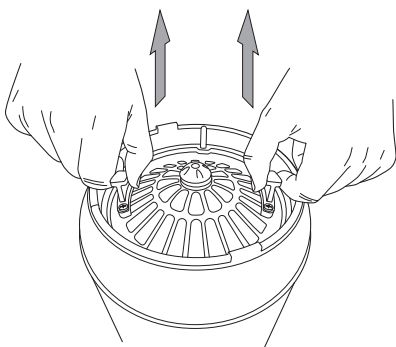

STEP 10

Pull up on the Top Cap to seat o-rings.

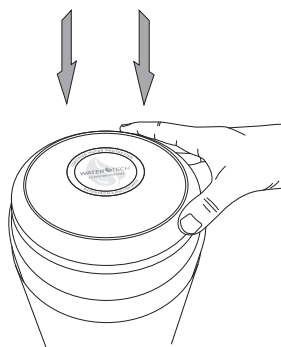

STEP 11

Place Umbrella Cap on top of system.



STEP 12

Run water through system for **10 minutes** before use.

FILTER CARTRIDGE REPLACEMENT

1

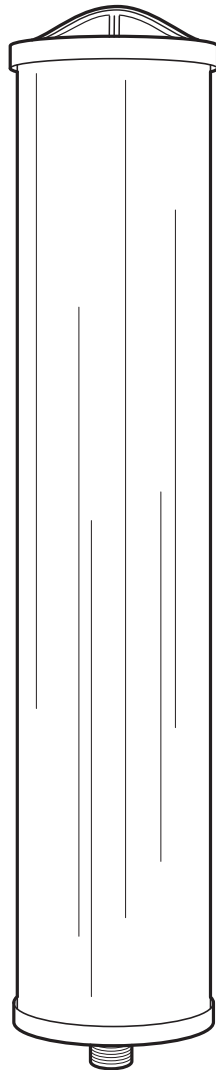
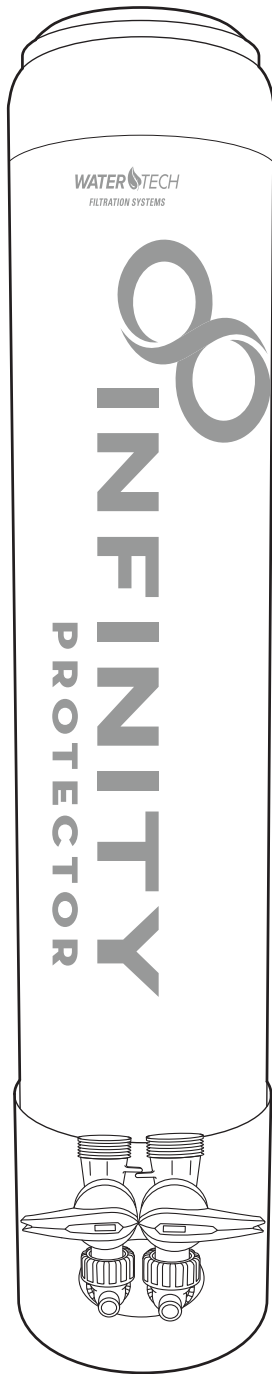

Filter Replacement
Part Number:
INF-PRO-FX1

Easy to understand LED Filter Replacement Notifications

The Real-time Dynamic LED System on the Umbrella Cap monitors water and flow rate and provides a visual color-coded notification, letting you know when the filter has reached certified capacity level at 100,000 gallons and to Replace the Filter.

GREEN LIGHTS = Filter Good

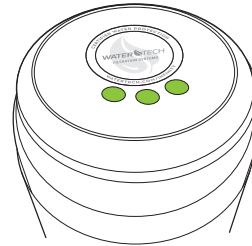

YELLOW LIGHTS = Change Soon 10% Filter Life Remaining

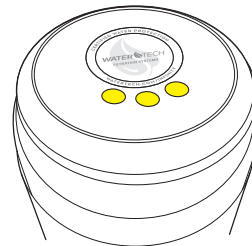

RED LIGHTS = Change Now

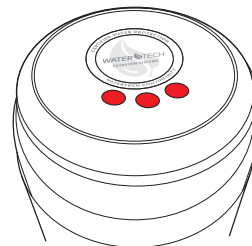

FILTER CARTRIDGE REPLACEMENT



**NO TOOLS
REQUIRED**

2

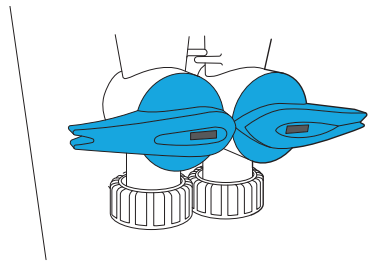

STEP 1

Turn off the water supply to the system by shutting off the inlet and outlet valves on the bypass.

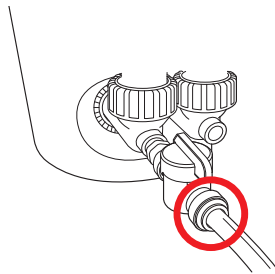

STEP 2

Install a 3/8" PEX tubing hose to the provided John Guest® fitting and shut-off that connects to the inlet side of the filtration system. Run the hose to a floor drain or bucket, and use to drain sediment or to aid in filter removal during change-out.

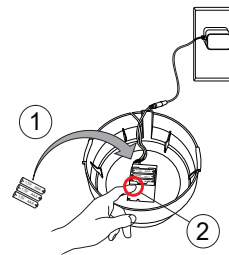

STEP 3

1. Remove Umbrella Cap on the top of the vessel. Replace the 3-AAA batteries with new batteries. 2. Push and hold the reset button on the circuit board for 3 seconds to reset the totalizer. When the totalizer is reset the LED lights will flash green 3 times to confirm that it is reset.

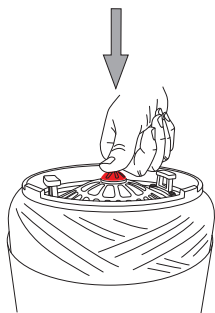

STEP 4

Depressurize the system by pushing down on the red depressurization button on the top cap of the system. Keep the button pushed down until all the air or water pressure is completely released.

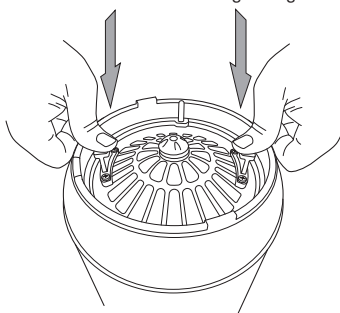

STEP 5

Push down the top cap with both hands to unseat the retaining ring.

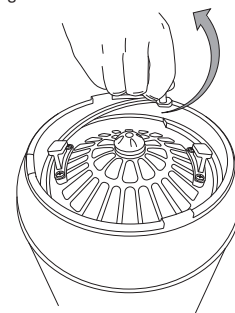

STEP 6

Remove the retaining ring by carefully grasping the handle and pulling inward, then upward. The retaining ring should slide completely out of the groove.

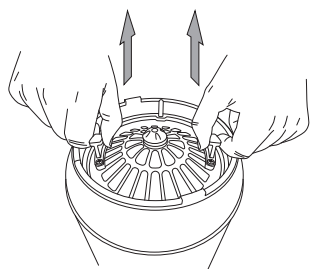

STEP 7

Remove the top cap of the system by lifting up on the top handles.



STEP 8

Remove old filter and discard.

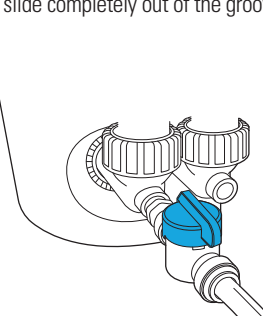

STEP 9

Open the John Guest® fitting shut-off, and flush out the bottom.

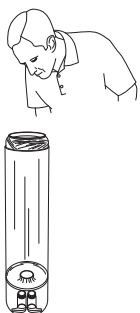

STEP 10

Look down into the tank assembly, and you should see a small opening centered in the bottom of the tank.



STEP 11

Remove packaging from the new filter cartridge and place into the tank with the double O-ring facing down.



STEP 12

Position the filter cartridge so that it is aligned with the bottom, center opening.

FILTER CARTRIDGE REPLACEMENT



**NO TOOLS
REQUIRED**

3

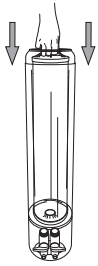

STEP 13

Press down on the filter cartridge so that the double O-ring seal moves into place within the bottom, center opening.

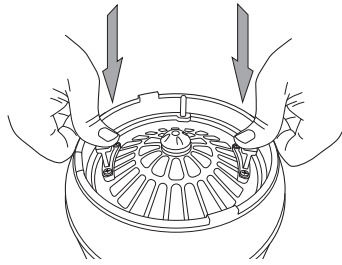

STEP 14

Reposition the Top Cap into its original location.

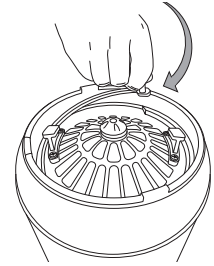

STEP 15

Reattach the top tank Snap Ring.

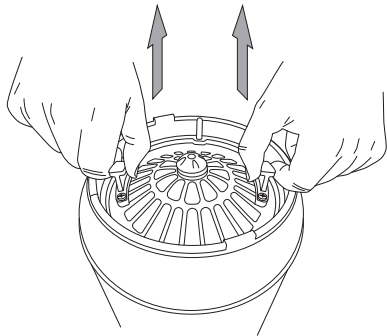

STEP 16

Pull up on the Top Cap to seat o-rings.

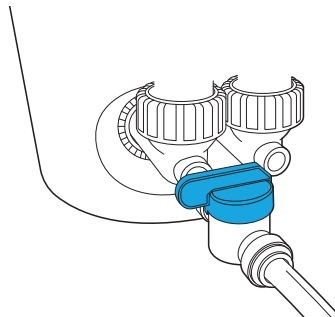

STEP 17

(If completed Step 2, then...) Close the John Guest® fitting and shut-off.

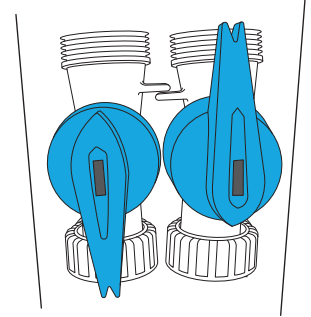

STEP 18

Turn the water supply on, opening the inlet and outlet valves on the bypass.

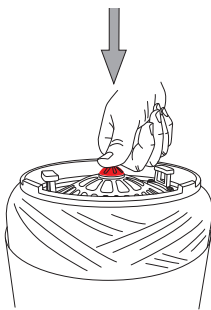

STEP 19

Relieve the system of air in the tank as the system fills with water, by pushing down on the red depressurization button on the top cap of the system. Keep the button pushed down until all the air pressure is completely released, and water comes out of the red depressurization button.

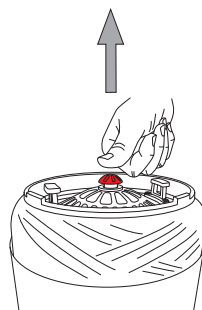

STEP 20

Release the red depressurization button.

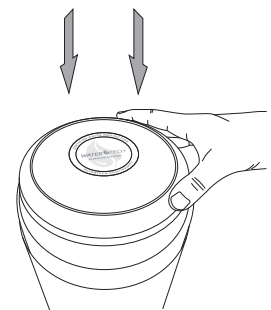

STEP 21

Replace the Umbrella cap to the top of the system.



STEP 22

Check for leaks.



STEP 23

Run water through system for **10 minutes** before use.

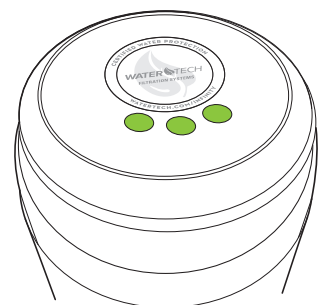

STEP 24

During flush, confirm green LED lights are flashing with flowing water. If lights are not flashing green, go back to step 3.

CERTIFIED WATER FILTER SYSTEM



NAME AND PART NUMBER	SIZE & MICRON RATING	RATED CAPACITY & FLOW RATE	PEAK FLOW & % REDUCTION OF LEAD	CHLORINE/CHLORAMINE TASTE AND ODOR REDUCTION CAPACITY (*)	PRESSURE DROP SPEC
Infinity Protector INF-PR01	8" x 40" 0.5	Lead Reduction and PFOA/PFOS 100,000 gallons @ 4.51 GPM (378,541 Liters @ 17.1 lpm) @ 99.62% lead reduction @ 97.9% PFOA/PFOS reduction	8 GPM (30.2lpm) @ 99.62% reduction (*) >88,000 gallons at 8 GPM (333,116 Liters @ 30.2lpm)	>300,000 gallons @ 15 GPM (1,135,533 Liters @ 56.8 lpm) with greater than 90% reduction, estimated capacity using 2ppm of free chlorine. >150,000 gallons @ 8 GPM (567,812 Liters @ 30.3 lpm) with greater than 85% reduction, estimated using 3ppm of chloramine.	9 psid @ 4.51 GPM

REPLACEMENT CARTRIDGE FILTERS ARE LISTED AS Infinity Protector 0.5 Micron High Capacity Carbon Block // PART NUMBER: **INF-PR01-FX**

*Claims are not performance tested by IAPMO or NSF. Performance claims are based on independent laboratory and manufacturer's internal test data. Actual performance is dependent on influent water quality, flow rates, system design and application. Results may vary.

IMPORTANT

DO NOT USE extra lubricants, unapproved sealants and tools to tighten hand tightened only parts. Use of tools other than hand tighten only parts voids warranty. Testing was performed under standard laboratory conditions; actual performance may vary. Flush the system and change the filter as suggested. The contaminants or other substances removed or reduced by this water filter are not necessarily in all users' water.

PERFORMANCE

Performance claims are based on independent lab results and manufacturer's internal test data*. Actual performance is dependent on influent water quality, flow rates, system design and applications. Your results may vary. Performance claims are based on a complete system, including a filter, housing, and connection to a pressurized water source. This filter must be operated according to the system's specifications in order to deliver the claimed performance. It is essential to follow operational, maintenance, and filter replacement requirements, as directed for each application, for this filter and system to perform correctly. Read the Manufacturer's Performance Data Sheet accompanying the system and change the filter as suggested. The contaminants or other substances removed or reduced by this water filter are not necessarily in all users' water.

This system has been tested for the reduction of the substances listed below. The concentration of the indicated substances in water entering the system was reduced to a concentration less than equal to the permissible limit for water leaving the system, as specified in NSF/ANSI 53. Minimum substance reductions are as follows:

SUBSTANCE	INFLUENT CHALLENGE CONCENTRATION (MG/L)	MAXIMUM PERMISSIBLE PRODUCT WATER CONCENTRATION (MG/L)	NSF/ANSI STANDARD
Lead	0.15 +/- 10%	0.01	53
Cyst	minimum 50,000/L	99.95%	53
PFOA/PFOS	1.5 +/- 10%	0.07	53

Electrical Requirements: Grounded & Unswitched 115 V outlet and 3-AAA Batteries
Filter Replacement Operating Instructions: New cartridges must be flushed for a minimum of 10 minutes prior to use. System and installation to comply with state and local laws and regulations. Do not use with water that is microbiologically unsafe or unknown quality without adequate disinfection before or after the system. Systems certified for cyst reduction may be used on disinfected waters that may contain filterable cysts. Manufactured from NSF/ANSI standard 61 and California Prop 65 Compliant certified coconut shell carbon and raw materials.



This system is certified by IAPMO R&T against NSF/ANSI Standards 53 (also CSA B483.1) for the reduction of claims specified on the performance data sheet.



This pressure vessel is tested and certified by NSF International against NSF/ANSI Standard 44 and 61 for materials and structural integrity requirements

WARRANTY



WARRANTY

WaterTech Industries Infinity Protector Whole House Filter

Limited Warranty Applicable to: Infinity Protector

1. WATERTECH INDUSTRIES INC. (WaterTech) warrants its line of WATERTECH INFINITY PROTECTOR™ filtration systems, to be free of defects in material and workmanship for a period of one year, and replacement INFINITY PROTECTOR™ filters for a limited thirty-day warranty, from the date of purchase. This warranty is extended to original purchaser, by locally authorized WaterTech Dealers and Distributors. Use of this product constitutes Buyer's acceptance of this Limited Liability.
2. This warranty does not cover any equipment purchased for use in applications in which the product is not suited. It is the responsibility of the buyer to determine if a product is suitable for a particular application.
3. WaterTech's obligations under this warranty are limited to the repair or replacement (at WATERTECH INDUSTRIES' sole discretion) of the failed parts of the water treatment unit manufactured by WATERTECH INDUSTRIES, and we assume no liability whatsoever for direct, indirect, incidental, consequential, special, general or other damages. Cosmetic damage that does not affect the process functionality of the equipment is not covered. Water Tech makes every effort to ensure that all illustrations and specifications are correct. However, these do not imply a warranty that the product is merchantable or fit for a particular purpose, or that the product may not vary from the illustrations and specifications.
4. WaterTech assumes no liability for the determination of the proper equipment necessary to meet your requirements, and we do not authorize others to assume such obligations for us.
5. WaterTech assumes no liability and extend no warranties, expressed or implied, for the use of this product with a non-potable water source or a water source which does not meet the conditions for use described in the owner's guide or performance data sheet for the product.
6. The warranty provided herein applies, only when used within the product specifications and service life, from the date of installation, beyond which WATERTECH INDUSTRIES INC. is absolved of any and all liability for any use of the product. There are no other warranties, either of merchantability or fitness, either expressed or implied. Some states do not allow exclusion or limitation of incidental or consequential damages. This warranty gives you specific legal rights, and you may also have other rights which vary from state to state, or country to country. To know what your legal rights are, consult your local or state consumer affairs office, your state's Attorney General, or your national equivalent for international users.
7. THIS WARRANTY EXCLUDES THE FOLLOWING:
 - a. Damage caused by improper installation, operation or care.
 - b. Damage caused by chemical attack, environment, accident, fire, flood, freezing, Act of God, misuse, misapplication, neglect, oxidizing agents (such as chlorine, ozone, chloramines and other related components), alteration, installation or operation contrary to the printed instructions, or by the use of accessories or components which do not meet WATERTECH INDUSTRIES'S specifications, including the use of a replacement element not manufactured or supplied by WATERTECH INDUSTRIES INC.. Refer to the specifications section in the Installation and Operating manual for approved application parameters.
 - c. Modification or alteration by other than WATERTECH INDUSTRIES INC. employees.
 - d. Rubber type parts and normal wear items i.e. "O" rings, etc.
 - e. Any costs of labor or expenses expended in the removal and/or installation of unit, or any surrounding device.
 - f. Altering or removing the WATERTECH INDUSTRIES INC. information label.
 - g. Use of non WATERTECH INDUSTRIES INC. approved cartridges, filters, or replacement parts with the appropriate systems or vessels.
 - h. Non-use of supported piping for plumbing connections to In/Out connections.
 - i. Replacement of water filter cartridge due to water pressure that is outside the specified operating range or due to excessive sediment in water supply; or replacement with non-authorized replacement cartridge.
 - j. Service trips to installation site to train user on how to use product.
 - k. Improper installation.
 - l. Failure of product if it is abused, misused, or used for other than the intended purpose.
 - m. Incidental or consequential damage caused by possible defects with any other equipment not covered by this warranty.
8. SPECIAL NOTICES:
 - a. Do not use water that is microbiologically unsafe or of unknown quality without adequate disinfection before or after installing filter or system.
 - b. Systems certified for Cyst reduction may be used on disinfected water that may contain filterable cysts.
 - c. Any system this filter is installed in must be maintained according to manufacturer's instructions, including replacement of filter cartridges.
 - d. Contaminants or other substances removed or reduced by this water filter cartridge are not necessarily in your water.
 - e. Note that while testing was performed under standard laboratory conditions, actual performance may vary. Systems using these filters must be installed and operated in accordance with manufacturer's recommended procedures and guidelines.
9. Service under this warranty is to be provided by the dealer/distributor/installer who sold the unit to the user. If the distributor is unable to provide warranty service, contact WaterTech.

Product Warranty Registration:

WaterTech.com

WaterTech Industries Inc.

800 Freeport Pkwy, #150 | Coppell, TX 75019

469-521-1180

CustomerSupport@WaterTech.com

A Warranty claim must be handled by a locally authorized WaterTech dealer.

Please be prepared with the following information:

1. Model number and serial number.
2. Date of installation.
3. Name of installer/Company.
4. Nature of problem.
5. Your address and contact information.



www.WaterTech.com

WaterTech
800 Freeport Pkwy, #150 | Coppell, TX 75019
469-521-1180
CustomerSupport@WaterTech.com